



DEEP CYCLE AGM TECHNOLOGY

DEEP CYCLE AGM BATTERY

LDC12-330-8D BCI GROUP 8D

FEATURES & BENEFITS

- True deep cycle AGM technology-GREEN SOLUTION
- Over 99.99% virgin lead for grid plate and active material
- Heavy duty grid/paste design for deep cycle application
- Maintenance free, non-spillable, valve-regulated
- Double separator configuration: long cycle life & High energy density and super anti-vibration design
- Low self-discharge for longer shelf life



ELECTRICAL SPECIFICATIONS

Voltage(V)	Capacity (AH)					Reserve Capacity (Min)		
	100HR	20HR	10HR	5HR	3HR	@25A	@56A	@75A
12	355	330	308	280	268	740	/	207

PHYSICAL SPECIFICATIONS

Model	Dimensions (mm/inches)				Weight (kg/lbs)	Terminal Type (Standard)	Case Material
	Length	Width	Height	Total Height			
LDC12-330-8D	527 (20.75)	280 (11.02)	230 (9.06)	252 (9.92)	86.0 (189.6)	DT-3/8	PP

Operating Temperature Range		
Discharge	Charge	Storage
-15°C~50°C(5°F~122°F)	0°C~40°C(32°F~104°F)	-15°C~40°C(5°F~104°F)



TS16949

ISO14001

ISO9001

OHSAS18001

LDC12-330-8D

DIMENSIONS

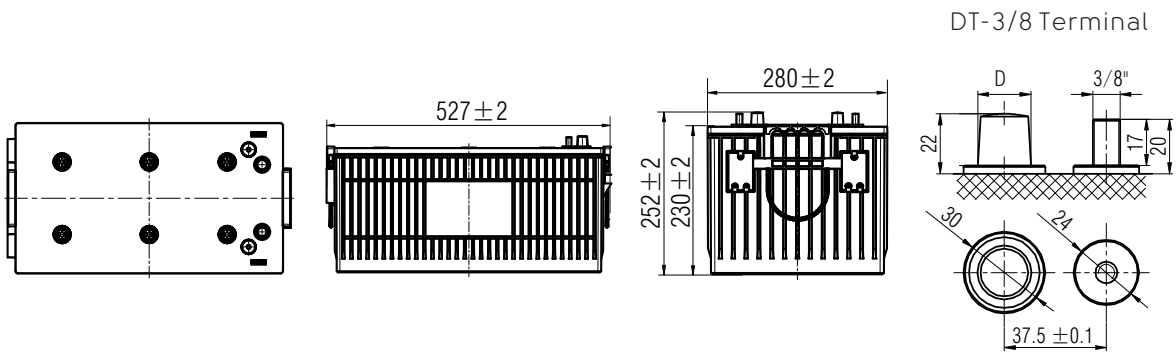

Note: D:Positive $19.5_{-0.3}^0$, D:Negative $17.9_{-0.3}^0$; Terminal Torque Values in-lb(Nm) : 176-203(20-23)

PERFORMANCE CHARACTERISTICS

LEOCH LDC AGM Charging Profile

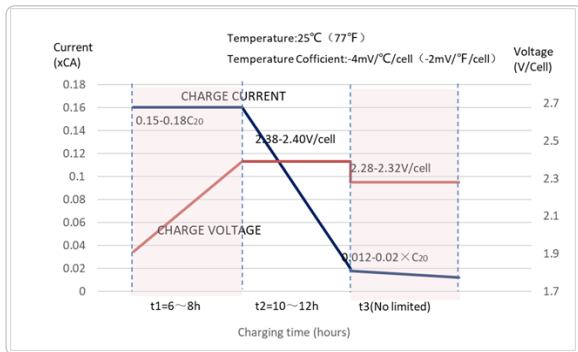

Relationship of OCV and State Of Charge ($25^{\circ}\text{C}, 77^{\circ}\text{F}$)

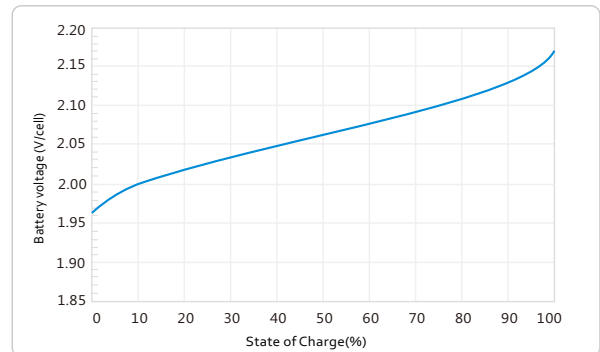

Cycle life in relation to Depth Of Discharge

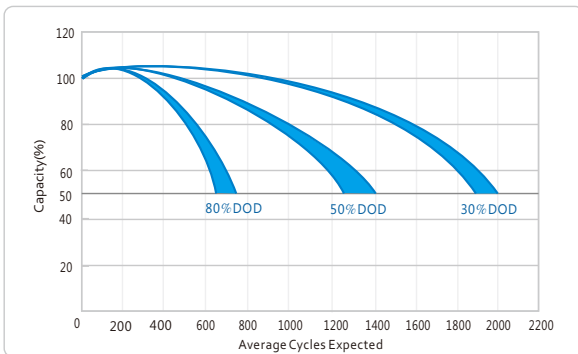

Self-discharge Characteristic

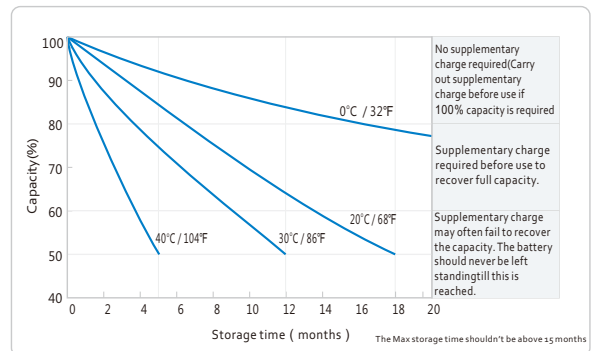

● LEOCH BATTERY CORP. USA:
19751 Descartes, Foothill Ranch, CA 92610 USA
Tel: 949-588-5853 E-mail: sales@leoch.us



DEEP CYCLE AGM BATTERY